

## SUPER ION AIR WIPE INSTALLATION & MAINTENANCE

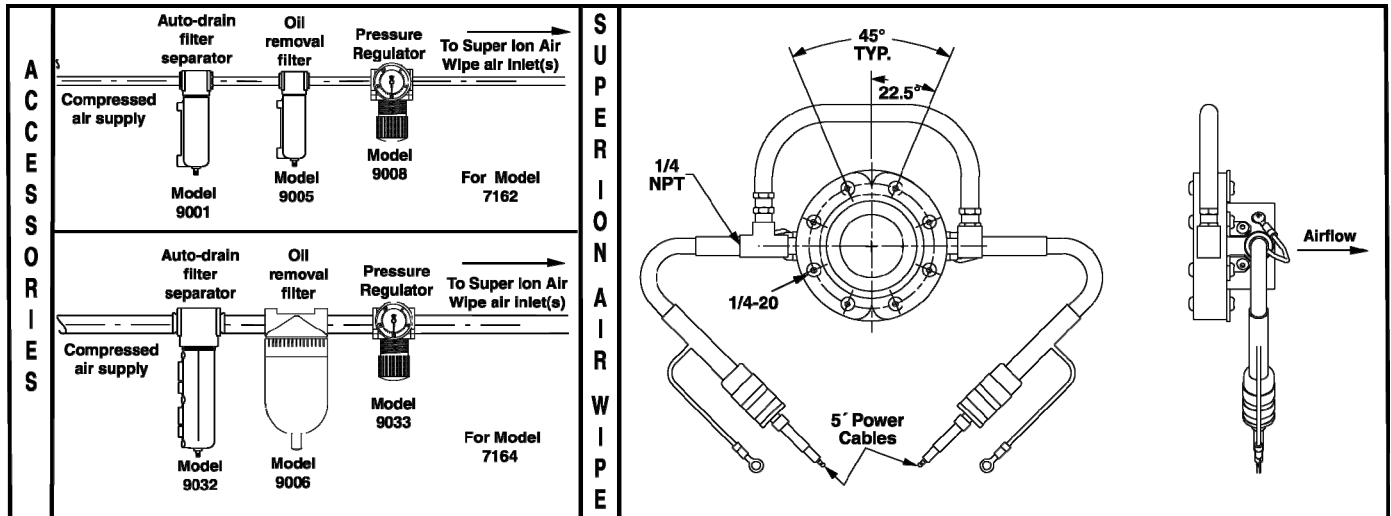

### COMPRESSED AIR LINE SIZES

Compressed air lines should be sized to hold pressure drops to a minimum. Do not use restrictive fittings or undersized lines that can starve the Super Ion Air Wipe by causing excessive line pressure drop.

SUPER ION AIR WIPE RECOMMENDED INFEED PIPE SIZES				
Super Ion Air Wipe Size	Model Numbers	Infeed Pipe Size		
		Length of Run		
		10' (3m)	50' (15.2m)	100' (30.5m)
2" (51mm)	7162	3/8"	1/2"	3/4"
4" (102mm)	7164	1/2"	3/4"	1"
If hose is used instead of pipe, use the next larger size for proper airflow (1/4 pipe = 3/8 hose).				

SUPER ION AIR WIPE RECOMMENDED FILTERS AND REGULATORS			
Super Ion Air Wipe Model #	Filter-Separator Model #	Oil Removal Filter Model #	Pressure Regulator Model #
7162	9001	9005	9008
7164	9032	9006	9033
See the chart above for proper filter and regulator recommendations for each Super Ion Air Wipe model.			

### COMPRESSED AIR SUPPLY

With proper filtration and separation of dirt, moisture and oil from the compressed air supply, the Super Ion Air Wipe will operate for years with no maintenance required. Use a 10 micron or smaller filter separator on the compressed air supply.

To prevent problems associated with oil, use an oil removal filter. The Oil Removal Filter should be used downstream from the Automatic Drain Filter Separator. Filters should be used close to each Super Ion Air Wipe, within 10' to 15' (3 to 4.6m) is best.

The Super Ion Air Wipe is designed to use normal shop air supplies up to 100 PSIG (6.9 BAR). For infinite control of flow and force, pressure may be regulated.

### USING THE SUPER ION AIR WIPE

The Super Ion Air Wipe is supplied with coupling brackets for each half. One bracket is designed to remain stationary while the other has a notch for latching the two halves together.

All models include stainless steel screws and shims. There is a 1/4 NPT female inlet on each half of the Super Air Wipe. Super Ion Air Wipes include a brass tee that supplies one half directly and a stainless steel wire braided coupling hose to supply the other half.

The air flows from the side with the screw heads to the opposite side. It is best to position the Super Ion Air Wipe so the material running through the center is evenly spaced from all surfaces.

For mounting, there are tapped holes on the back of the Super Ion Air Wipe. It can also be held in place with rigid pipe.

The Super Ion Air Wipe is supplied with a .002" (.05mm) thick shim in each half. If additional hard-hitting force is required, additional shims are available.

### **SUPER ION AIR WIPE SHIM SET**

Force and flow from the Super Air Wipe may be easily increased by adding shims to open the air gap. The Super Ion Air Wipe is supplied with a .002" (.05mm) thick shim installed. It sets the air slot to a .002" (.05mm) opening. To increase the air gap, use a shim set (included with the Super Ion Air Wipe Kit). The shim set includes (2) .002 (.05mm) thick stainless steel shims. By changing and stacking them, gaps may be set from .002" to .004" (.05mm to .10mm). Individual shims are available.

To change shims, remove the assembly bolts. Inspect the Super Ion Air Wipe and shim(s) to assure no dust, dirt or chips are on the mating surfaces or in the plenum chamber. Replace or add a shim(s), and retighten bolts to 7.5 ft. lbs. Note that mating parts (body and cap) do not align flush. The air opening cannot be dead ended, which meets OSHA requirements.

### **ELECTRICAL SUPPLY**

The Model 7901 Power Supply (two outlet) and Model 7940 Power Supply (four outlet) require a 115V, 50/60Hz source. The Model 7907 Power Supply (two outlet) and Model 7941 Power Supply (four outlet) require a 230V, 50/60Hz source. For proper operation, the Super Ion Air Wipe and power supply must be properly grounded. If the unit is not grounded, the Super Ion Air Wipe will produce a shock and will not function properly. The ground terminal on the power supply must be connected to the grounding wire of the Super Ion Air Wipe. A common ground to a machine can be obtained by attaching the Super Ion Air Wipe and the power supply to the metal frame of the machine. On permanent installations, it is recommended that the ionizer cable be shielded in plastic conduit or otherwise insulated from grounded metal surfaces for optimum performance.

### **TROUBLESHOOTING AND MAINTENANCE**

**If There Is A Reduction In Flow Or Force From The Super Ion Air Wipe**, check the pressure by installing a gauge at the compressed air inlet. Large pressure drops are possible due to undersized lines, restrictive fittings and clogged filter elements.

**For replacement or repair filter and regulator parts, contact EXAIR at 1-800-903-9247 or [techelp@exair.com](mailto:techelp@exair.com). Call (513) 671-3322 for outside the US and Canada.**

### **CLEANING**

If contaminants have clogged the Super Ion Air Wipe, inspect the unit by disassembling. The Super Ion Air Wipe consists of two component parts and between them is a shim that sets the gap the compressed air exhausts through. Inspect each part for dust or dirt contamination and a possible oil film in the area of the slotted nozzle. Clean each part and retighten bolts.

Occasionally there is a buildup which occurs on the face of the Super Ion Air Wipe as a result of vapors in the atmosphere. Clean this surface with solvent and a clean rag. To prevent contaminants from getting pushed back into the slot, perform this procedure with a small amount of compressed air passing through the Super Ion Air Wipe.

If you have any questions or problems, please contact:

Airtec Servicios  
Av. Colorines # 621-26, San Luis Potosi, Mexico  
Tel: 52+ 444 8180960 Fax: 52+ 444 8189512  
Email: [info@airtec-servicios.com](mailto:info@airtec-servicios.com)  
Website: <http://airtec.exair.com>



Power supplies are UL Listed to U.S. and Canadian safety standards. There are no user serviceable parts inside.



Power Supplies meet the requirements of applicable European Directive(s).

